



Dry Bath Incubator GA150 series

Manual



Hangzhou Yooning Instrument Co., Ltd.

Address : 4 floor, #6 Building, No.3 Shengang Road,
Yuhang District, Hangzhou, China

Customer Service : +86-571-86907383 / 87613616

Website: www.yooning.com

Hangzhou Yooning Instrument Co., Ltd.

General Information

Thank you for purchasing our Products.
This Manual for users contains function and operation of the Instrument. In order to use the instrument properly, please read this manual carefully.

Please check the instrument and accessories with the packing list at the first time you open the instrument packing case.

Appendix 1: GA150 Wiring Diagram

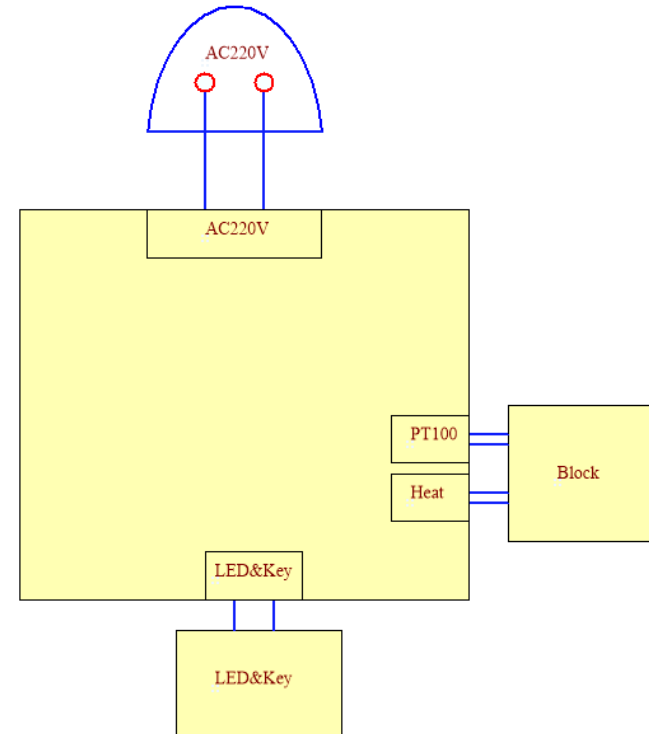

Packing List

No.	Item	Model/Type	Quantity	Confirm	Remarks
1	Dry Bath Incubator	<input type="checkbox"/> GA150-1 <input type="checkbox"/> GA150-2 <input type="checkbox"/> GA150-4	1		
2	Manual		1		
3	QC PASS Card		1		
4	Power Cable		1		
5	Allen Wrench	M4	1		
6	Screws	M3X10	2		With washer
7	Block Handle	M4	1		
8	Fuse		2		
Confirmer: _____ Date : _____					

Contents

1.Importatn Instruction.....	1
1.1 Safety Instruction.....	1
1.2 Safety.....	1
2.Brief Introduction.....	3
3.Product Features	4
3.1 Working Conditions.....	4
3.2 Basic Parameters.....	4
3.3 Optional Blocks.....	5
4. Operation Instruction	6
4.1 Structure	6
4.2 Face Panel	7
4.3 Key Functions.....	7
5.Operation Guides.....	8
5.1 Settings of Temperature and Time.....	8
5.2 Start/Stop.....	9
6. Temperature Calibration	10
7.Exchange Blocks.....	12
8.Troubles and Shootings	13
9.Instrument Maintenance	13
Performance Test	14
Packing List.....	15
Appendix 1 : GA150 wiring diagram	16

Performance Test

1. Important Instruction

1.1 Safety Instruction



Read this Manual carefully before using it. Read the guidelines and directions below to prevent injury and carry out countermeasure accordingly when necessary.

1.2 Safety

The operation, maintenance and repair of the instrument should comply with the basic guidelines and the remarked warning below.
If users don't comply with them, it will have an effect on the instrument.



This is a general device produced under standard GB9706.1, only use it in door where is ventilated well.
Only trained person can operate this instrument. Users or person who are not permitted are not allowed to open device, which will cause electricity shock or other danger.
Please contact factory for maintenance.



For safety use, ensure the power supply with earth/ grounding socket.
Make sure the voltage supplied is complied with indication on label.
Exchange the power cable once it is damaged.

Item		Dry Bath Incubator	Model	<input type="checkbox"/> GA150-1 <input type="checkbox"/> GA150-2 <input type="checkbox"/> GA150-4
Date			Serial No.	YN-
No.	Content	Methods	Standards	Results
1	Heating Rate	Calculagraph	≤30min(20°C to 150°C)	<input type="checkbox"/> Qualified
2	Temperature stability@40°C	Precise thermometer	≤±0.3°C	<input type="checkbox"/> Qualified
3	Temperature stability@100°C	Precise thermometer	≤±0.5°C	<input type="checkbox"/> Qualified
4	Temperature stability@120°C	Precise thermometer	≤±1°C	<input type="checkbox"/> Qualified
5	Temperature uniformity	Precise thermometer	≤±0.5°C	<input type="checkbox"/> Qualified
6	Temperature fluctuation	Multi channel detector	≤±0.5°C	<input type="checkbox"/> Qualified
7	Temperature control range	Thermometer	RT+5°C~ 150°C	<input type="checkbox"/> Qualified
8	Basic Function	Visual check	Valid	<input type="checkbox"/> Qualified
9	Safety test	Dedicated device	Pass	<input type="checkbox"/> Qualified
10	Continuous Running Test	Visual check	72H without problem	<input type="checkbox"/> Qualified
Result				
Remarks:				
QC:			Confirmer:	

8. Troubles and Shootings

No.	Troubles	Causes	Shootings
1	The actual and displayed temperatures are quite different	Broken sensor	Contact vender
2	Display does not work after device turned on	No power supply	Check the connection of power
		Fuse burned	Exchange fuse
		Broken switch	Exchange the switch
		Others	Contact vender
3	Button not working	Broken button	Contact vender
4	Device could not heat up to target temperature	Temperature sensor defect	Contact vender
		Heating controller IC defect	
		Heating tube defect	
5	ERR1	Block Sensor disconnected in circuit	Contact vender
6	ERR2	Block Sensor short out in circuit	Contact vender
7	ERR3	overheat	Contact vender



Don't place any stuff on the power cable, hold the plug head properly when pulling the cable off from the socket.

The metal heated block can reach a high temperature during heating, probably leads to sample/liquid boiled out of tubes, which may cause injury, so it is prohibited to touch metal block by any part of your body during heating procedure.



The instrument should be placed in a room with low humidity, less dust, and away from water sources, direct sunlight and strong light sources.

The room should be well ventilated, and away from heating, fire and other heat sources, and interference of corrosive gas or strong magnetic field. Keep at least 30cm of space between other devices.



Power off when you finish your work. Pull off the connector plug when there's long time no use of the Instrument and cover it with a cloth or plastic paper to prevent from dust.



Pull the connector plug from the jack at once in the following case, and contact the vendor:

- There is some liquid flowing into the Instrument
- Drenched or fire burned
- Abnormal operation: such as abnormal sound or smell
- Instrument dropping or outer shell damaged
- The function has obviously changed

9. Instrument Maintenance

The block and wells should be cleaned by the cloth stained with alcohol to assure good heat transmission between the block and the test tube and no pollution.



Power off when cleaning the instrument when cleaning the well, don't drop the cleaning liquid in the well; Corrosive cleaning liquid is strongly prohibited.

2. Brief Introduction

GA150 digital dry bath is controlled by microcomputer, widely used in preservation and reaction of the samples, DNA amplification and pre-denaturation of electrophoresis, serum coagulation, etc.

The features:

- LED display with timer and temperature on
- Various blocks for options, easy to clean and disinfect
- Automatic overheat detection with buzzer alarm
- Temperature calibration function
- The instrument will stop work with over-high temperature
- Buzzer alarm after program runs out.

7. Exchange blocks

7.1 Remove the two screws which fix the block by the screwdriver.

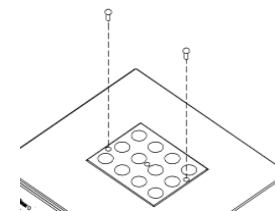

7.2 Fix the block lifter in the center well of the block.

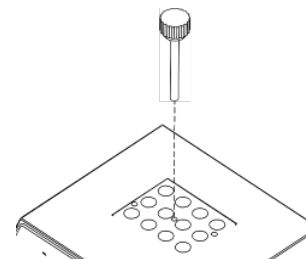

7.3 Lift upward the block lifter and take out block.

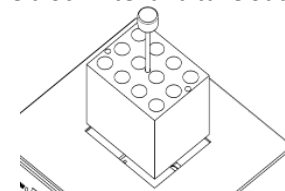

7.4 Place the needed block you into the instrument, fix the block screws.

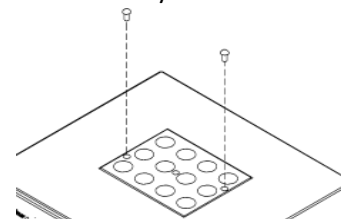

4) The dot stops flickering once temperature reaches at 40.0°C, and keep instrument heating at this temperature at least 20 minutes and read the thermometer.

Note: Keep instrument heat at temperature of 40.0°C at least for 20 minute will help instrument get a accurate temperature.

Then, read thermometer, if it reads 39.9°C, press buttons   correct the value to 39.9 for Temp. Press button  confirm.

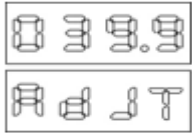

5) Instrument will heat up to next temperature point of 80°C, repeat steps above to calibrate.

6) Instrument will heat up to 120°C automatically after 80 °C calibration. Repeat steps as above.

Press button  to confirm. Calibration is completed.

Note: During calibration, if user wants to stop, just turn off power switch to quit.

3.Product features

3.1 Working Conditions

Ambient temperature: 5°C - 30°C

The relative humidity: ≤70%

Voltage: AC100-120V/ AC200-240V ,50/60Hz

3.2 Basic parameters

Model	GA150-1	GA150-2	GA150-4
Temperature Control Range	RT+5°C~150°C		
Temperature stability@40°C	±0.3°C		
Temperature stability@100°C	±0.5°C		
Temperature stability@120°C	±1°C		
Timer	1m-99h59m, 0 (infinite)		
Display accuracy	0.1°C		
Heating up Rate	≤30 min (20°C to 150°C)		
Voltage	AC100~120V/200~240V , 50/60Hz		
Power	200W	400W	600W
Dimension WxDxH (mm)	220x260x100	220x260x100	220x360x100

3.3 Optional blocks

Type	For tube diameter	Capacity
D1	6mm	48
D2	7mm	48
D3	10mm	24
D4	12mm	24
D5	13mm	24
D6	15mm	12
D7	16mm	12
D8	19mm	12
D9	20mm	12
D10	26mm	8
D11	28mm	6
D12	38mm	3
D13	0.2ml	48
D14	0.5ml	48
D15	1.5ml	24
D16	2 ml	24

6. Temperature Calibration



The temperature has been calibrated by the manufacturer and can be re-calibrated following the steps specified below.

Note: Please do not attempt to re-calibrate the temperature unless necessary. Please place the instrument at room temperature below 35°C for calibration.

Steps as the following:

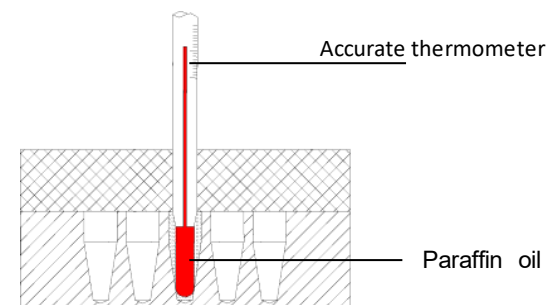
- 1) After the startup of the instrument, it enters waiting interface.
- 2) Inject olefin oil into one of the cone-shaped wells, and then put a thermometer into this well (Make sure the precision of the thermometer should be within 0.1°C and the temperature ball should be absolutely immersed into the cone-shaped well). Heat insulation material is needed on the block to separate it from the circumstance. Seeing from Fig a.



- 3) Press button  and  of Temp to start calibrate. Time window displays "Adjt", temperature displays the instant temperature of block with dot flickering, and instrument starts to heat up to 40.0°C.

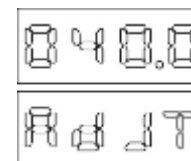

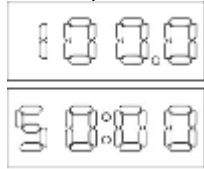

5.2 Start/Stop

1) Press button  to start program, instrument heats up and display of temperature area showing the instant temperature.

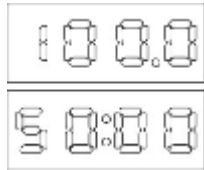

2) The dot of temperature value only stop flickering after instrument reaches target temperature. The symbol of “:” of timer flickers after the temperature reaches demanded value and timer starts to count down.



3) Buzzer alarms 5 times once program is over. Press  can run the program again. During program running, press button  to stop.

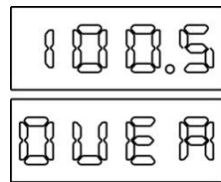

Note: During program running, instrument is unable to be set.

4. Operation Instruction

This chapter introduces the instrument mechanical structure, the navigation and each button's functions and some preparations before power-on. Please read it before first operation.



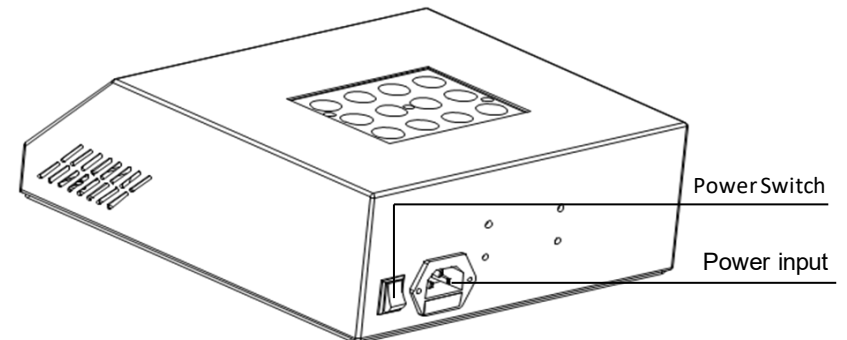
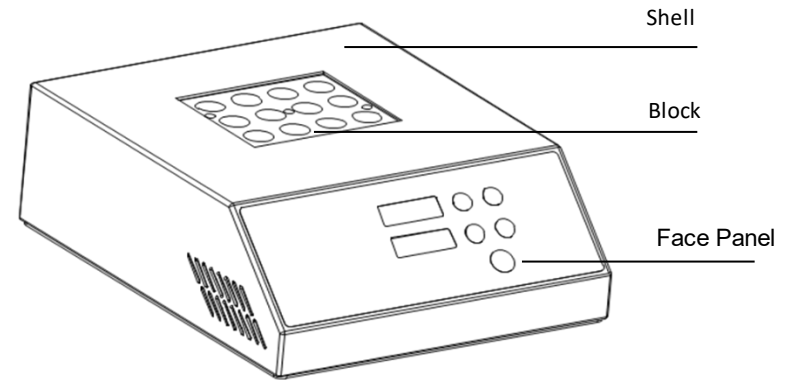

4.1 Structure

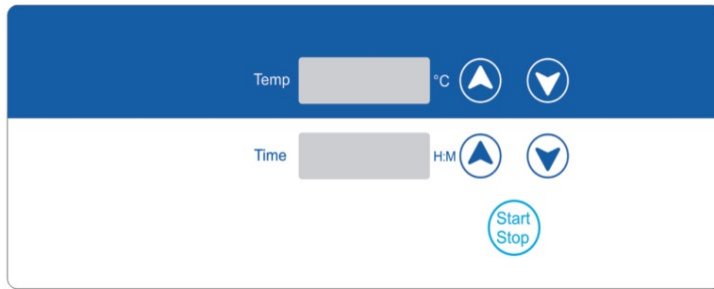

4.2 Face Panel



4.3 Buttons functions

- Temp.**  Temperature setting
Press shortly to revise temperature setting,
Press and keep can move the cursor.
- 
- Time**  Time setting
Press shortly to revise temperature setting,
Press and keep can move the cursor.
- 
-  Start/Stop. Press this button to confirm settings, and
program starts to run. Press again to stop.

5. Operation Guides

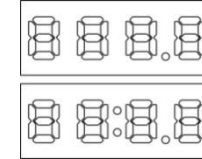

5.1 Settings of temperature and time

1) When the instrument powers on, it starts with the sound of “de...”

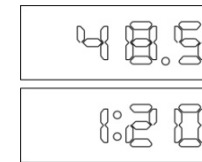

2) 2 seconds later, temperature on display showing block instant temperature of 48.5, 01:20 showing the last setting value of time.



3) Press button  or  to set temperature, press it again and hold for longer than 1 second to move cursor.
Set Time by similar way as above.
System will confirm new setting automatically when the cursor stop flickering.

